

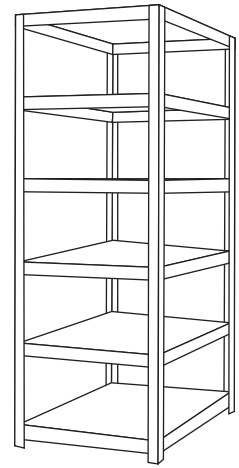

## 406 - Medium Duty Die Rack Assembly Instructions

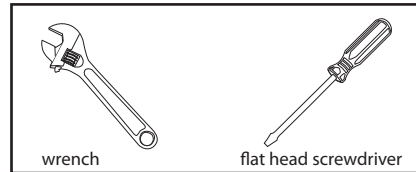



### Tools Needed:

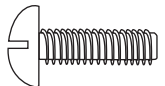

### Includes:

- (6) 16 Gauge Trays
- (4) 1 1/2" x 1 1/2" x 1/8" Angle Uprights

**96** x   
1/4" x 5/8" Round  
Head Machine Screw

**96** x   
1/4" Hex Nut

**96** x   
1/4" Lock Washer

### Steps:

**1** Lay (2) uprights on the ground as shown.

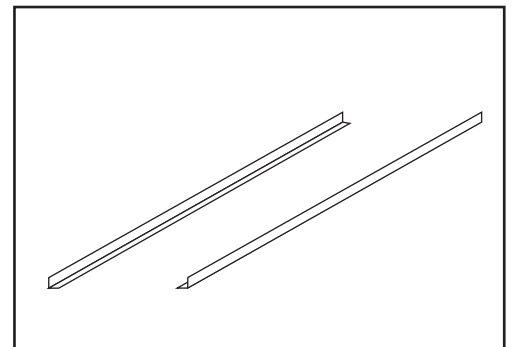

**2** Decide the location of your (6) Trays, and attach them to the Uprights using (48) 1/4" x 5/8" Round Head Machine Screws, 1/4" Hex Nuts, and 1/4" Lock Washers. **HAND TIGHTEN ONLY.**

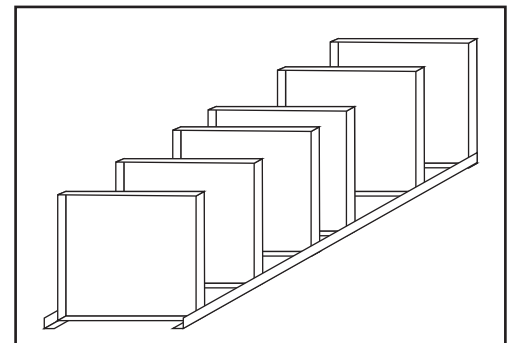

3

Attach Uprights to Trays using (48) 1/4" x 5/8" Round Head Machine Screws, 1/4" Hex Nuts, and 1/4" Lock Washers. **HAND TIGHTEN ONLY.**

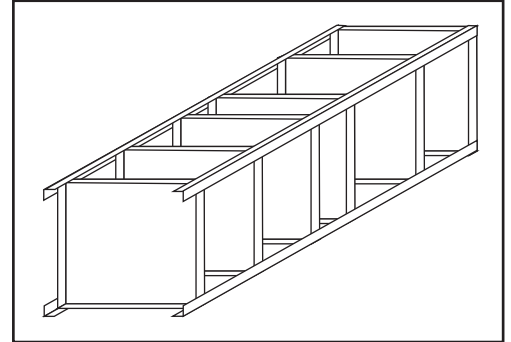

4

Turn Die Rack upright.

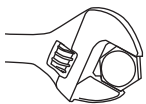
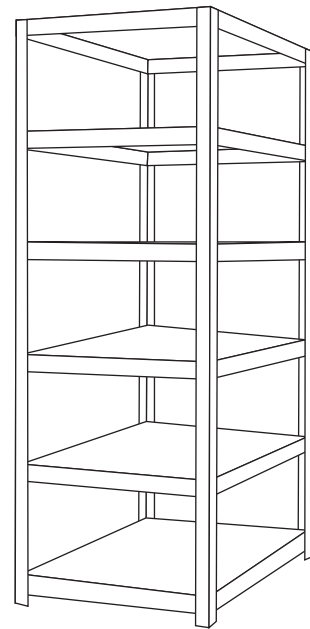

After rack is turned upright, make sure bench is square and then, tighten all bolts, starting with the stringer and tie rods.