

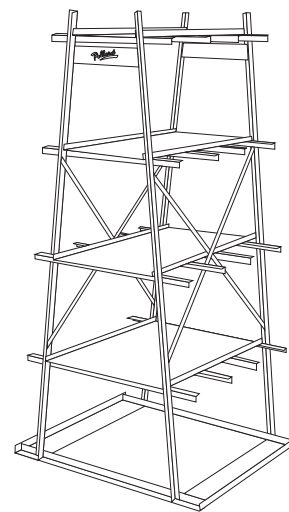

## 402 - Double Sided Vertical Bar Rack Assembly Instructions

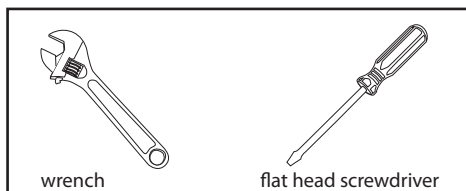

### Tools Needed:



wrench

flat head screwdriver

### Includes:

- (2) Welded Side Uprights [84 1/4" x 42"] • Top Shelf [13 1/4" x 36"] • 2nd Shelf [17 1/4" x 36"] • 3rd Shelf [21 1/2" x 36"]
- Bottom Shelf [25 1/2" x 36"] • (2) Base Plates [6" x 36" w/ 1 1/2" Lip] • (4) Cross Braces [1/8" x 1" x 50"]

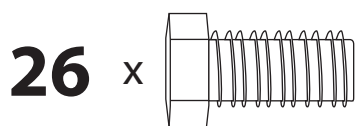

3/8" x 3/4" Hex Head  
Machine Screw



3/8" Hex Nut



3/8" Lock Washer

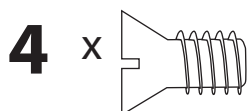

5/16" x 3/4" Flat Head  
Machine Screw

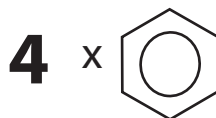

5/16" Hex Nut

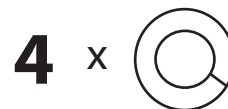

5/16" Lock Washer

### Steps:

*Pollard suggests that two people be utilized for assembly.*

# 1

Assemble Top Shelf to Welded Side Uprights using (4) 3/8" x 3/4" Hex Head Machine Screws, 3/8" Lock Washers, and 3/8" Hex Nuts. **HAND TIGHTEN ONLY.**

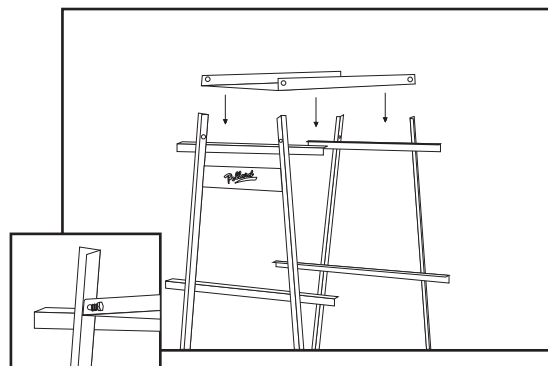

2

Assemble 2nd, 3rd, and Bottom Shelves the same way using (12) 3/8" x 3/4" Hex Head Machine Screws, 3/8" Hex nuts, and 3/8" Lock Washers. **HAND TIGHTEN ONLY.**

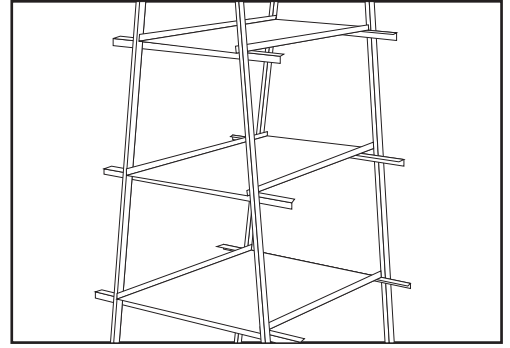

3

Assemble base plates to the bottom of the Welded Side Uprights using (4) 5/16" x 3/4" Flat Head Machine Screws, 5/16" Lock Washers, and 5/16" Hex Nuts. *Note: Tilting rack will assist assembly.*

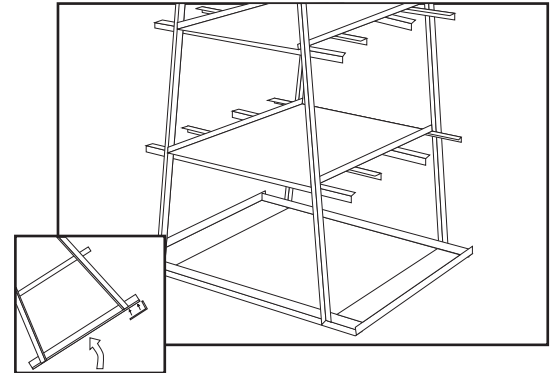

4

Assemble the Cross Braces to the rack, bolting to the 3rd and 5th set of holes on Uprights and the center hole on the 3rd Shelf using (10) 3/8" x 3/4" Hex Head Machine Screws, 3/8" Lock Washers, and 3/8" Hex Nuts.

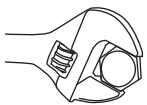
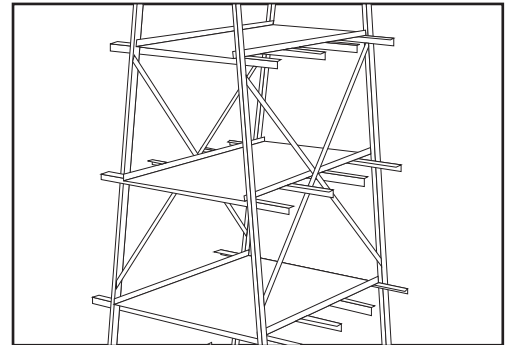

After braces are in place, make sure rack is square and then, tighten all bolts, starting with the shelves.